

# 4G Paddle Monopole Antenna

## FEATURES



- Designed for both Indoor & Outdoor applications
- Ground Plane dependent
- Full 4GLTE backward compatibility
- 4.0 dBi Peak Gain
- Small Form Factor



The MyAntenna M02-0500110R0A&M02-0500100R0A range of antennas are designed to decrease the lifetime cost of M2M and mobile device installations by offering a robust, effective antenna that is easy to install and lasts the lifetime of the installation without the need for maintenance.

The antenna offers ground-plane dependent Omni-directional performance across global cellular and LTE bands making it a versatile solution for any number of applications. The efficient element design ensures a high first time connection rate and an ongoing, robust communications link even in problematic coverage areas.

## PRODUCTS

Part No.	Weight	Dimensions (L x W x H)	Connector	Color
M02-0500110R0A	6g	47.6*17.2*8.2mm	SMA-Male	Black
M02-0500100R0A	6g	50.5*17.2*10.4mm	SMA-Male	Black

## SPECIFICATIONS

PARAMETER	SPECIFICATION	
Frequency Bands, MHz	698-960	1710-2690
VSWR (Max)	3.0:1	3.0:1
Peak Gain, dBi (Typ)	Up to 4.0	
Nominal Impedance	50 Ω	
Max Power (ambient temp of 25°C)	10 Watts	
Azimuth Beam Width (deg)	Omnidirectional	
Polarization	Linear, Omnidirectional	
Radome	TPE, Black	
Storage Temperature Range (°C)	-40° C to +85° C	
Operational Temperature Range (°C)	-30° C to +80° C	
Material Substance Compliance	REACH/RoHS Compliant	
HSCODE	8517707090	
USHSCODE	8517620010	
UPC		

MyAntenna RF Technology Co., Ltd

ADD: No.RM 405, R3-A Building, Shenzhen High-Tech Park, Nanshan, Shenzhen, P.R. China.

TEL: +86-0755-86503881 FAX: +86-0755-27801677 E-mail: [nfc@myantenna.com](mailto:nfc@myantenna.com)

**ELECTRICAL DATA**

Return Loss

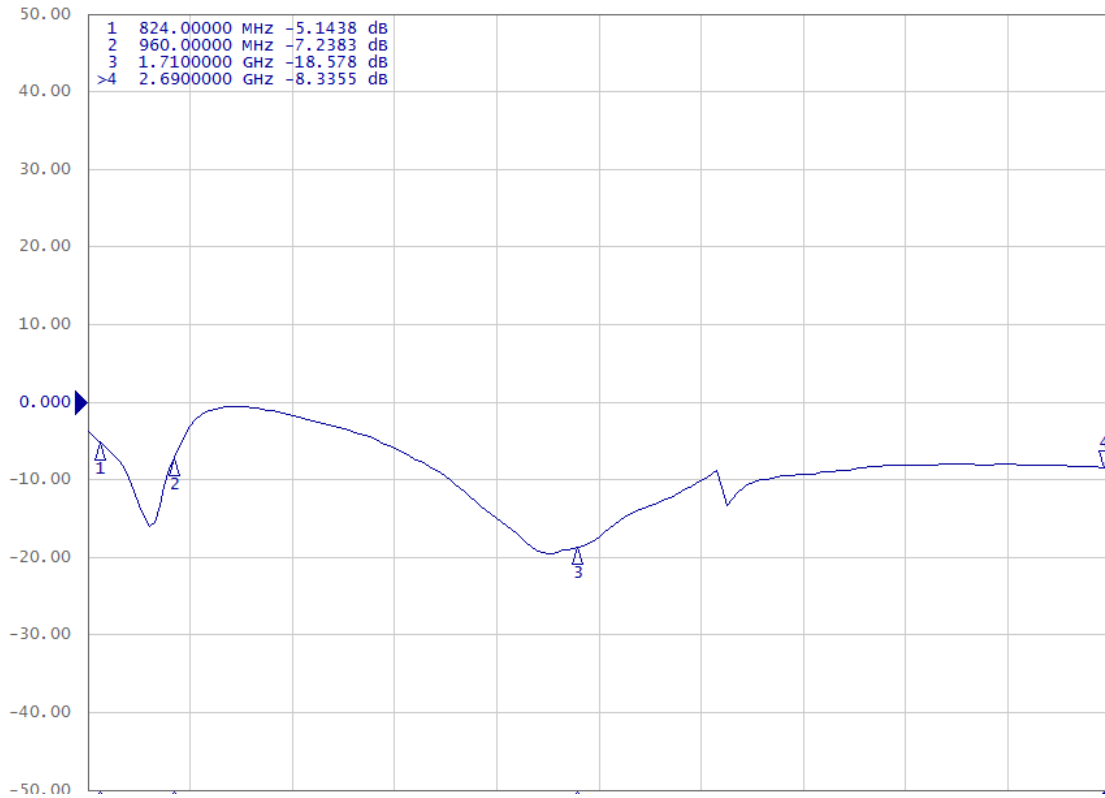

Efficiency (%)

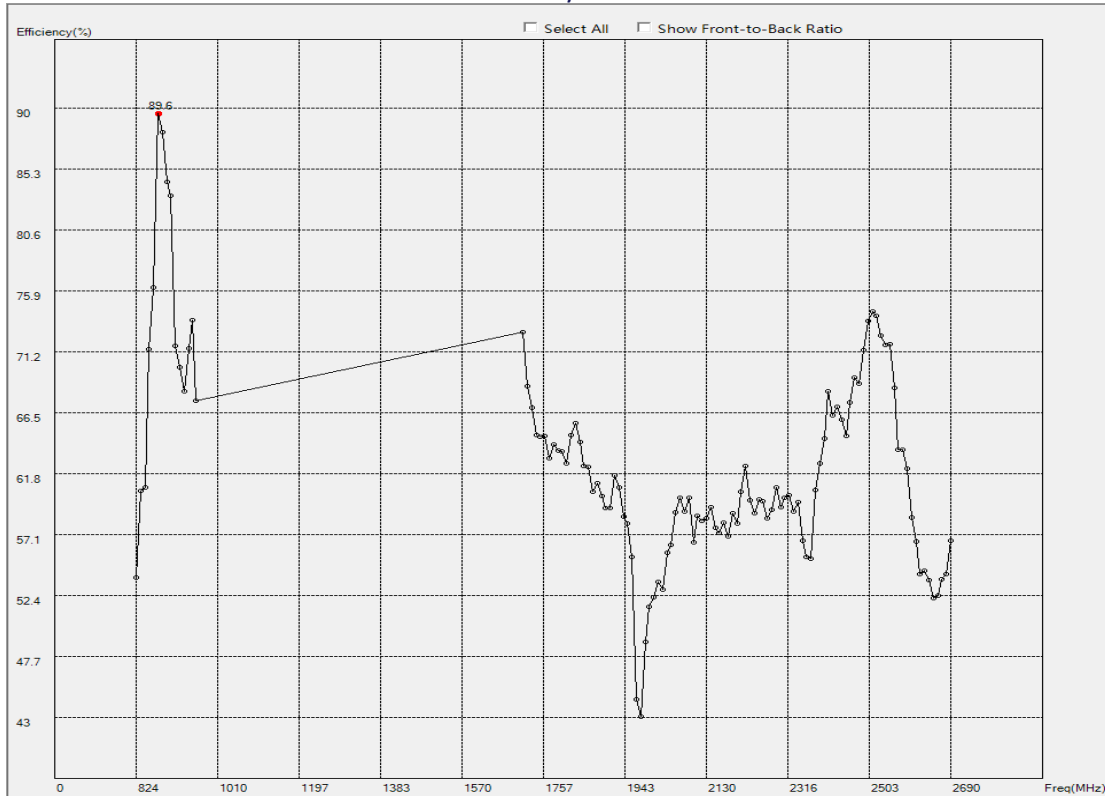

### Peak Gain (dBi)

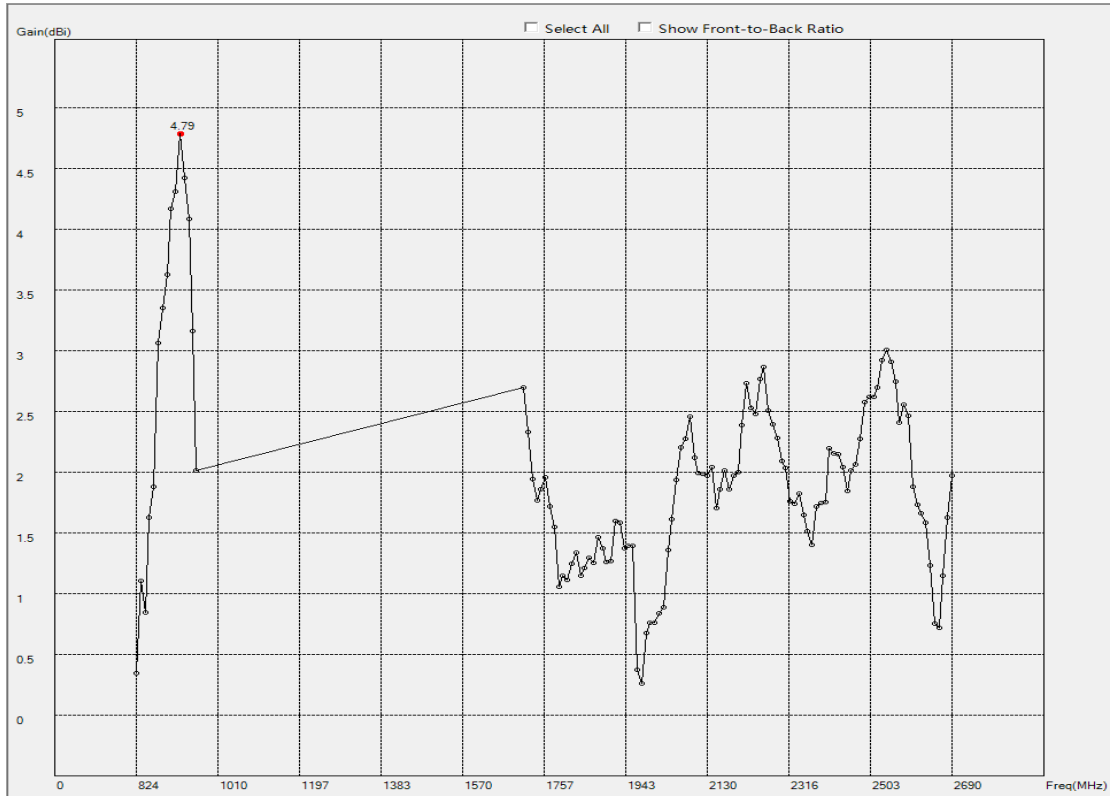

### RADIATION PATTERNS

#### 2D Radiation Pattern at 894MHz

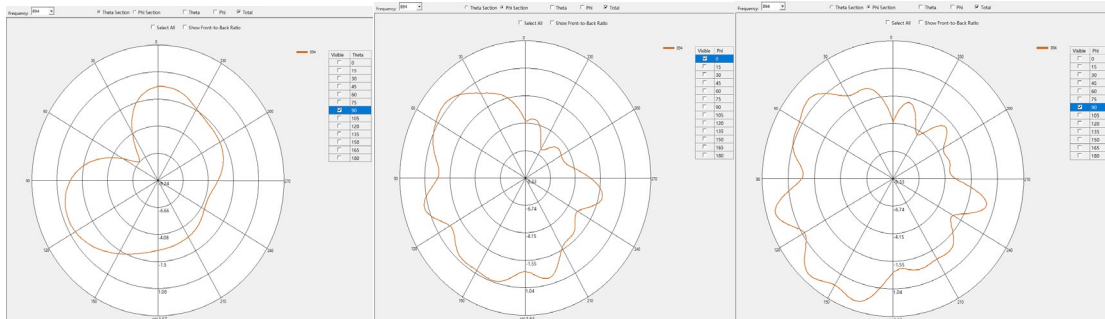

#### 2D Radiation Pattern at 2120MHz

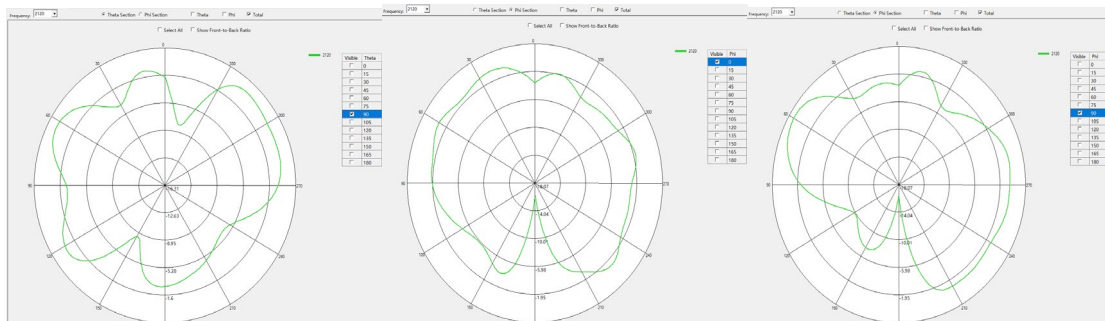

HOUSING CONFIGURATIONS

M02-0500100R0A

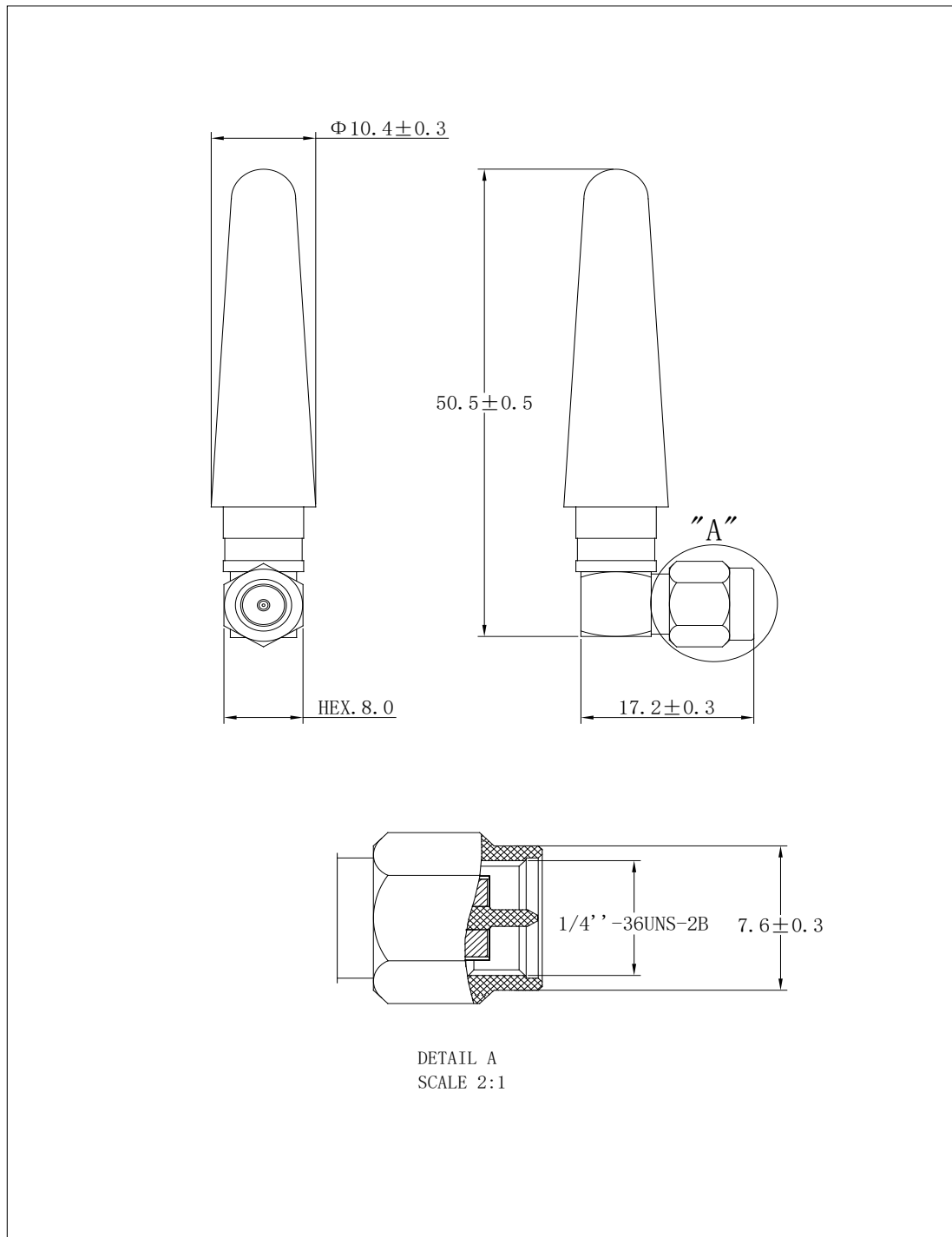

M02-0500110R0A

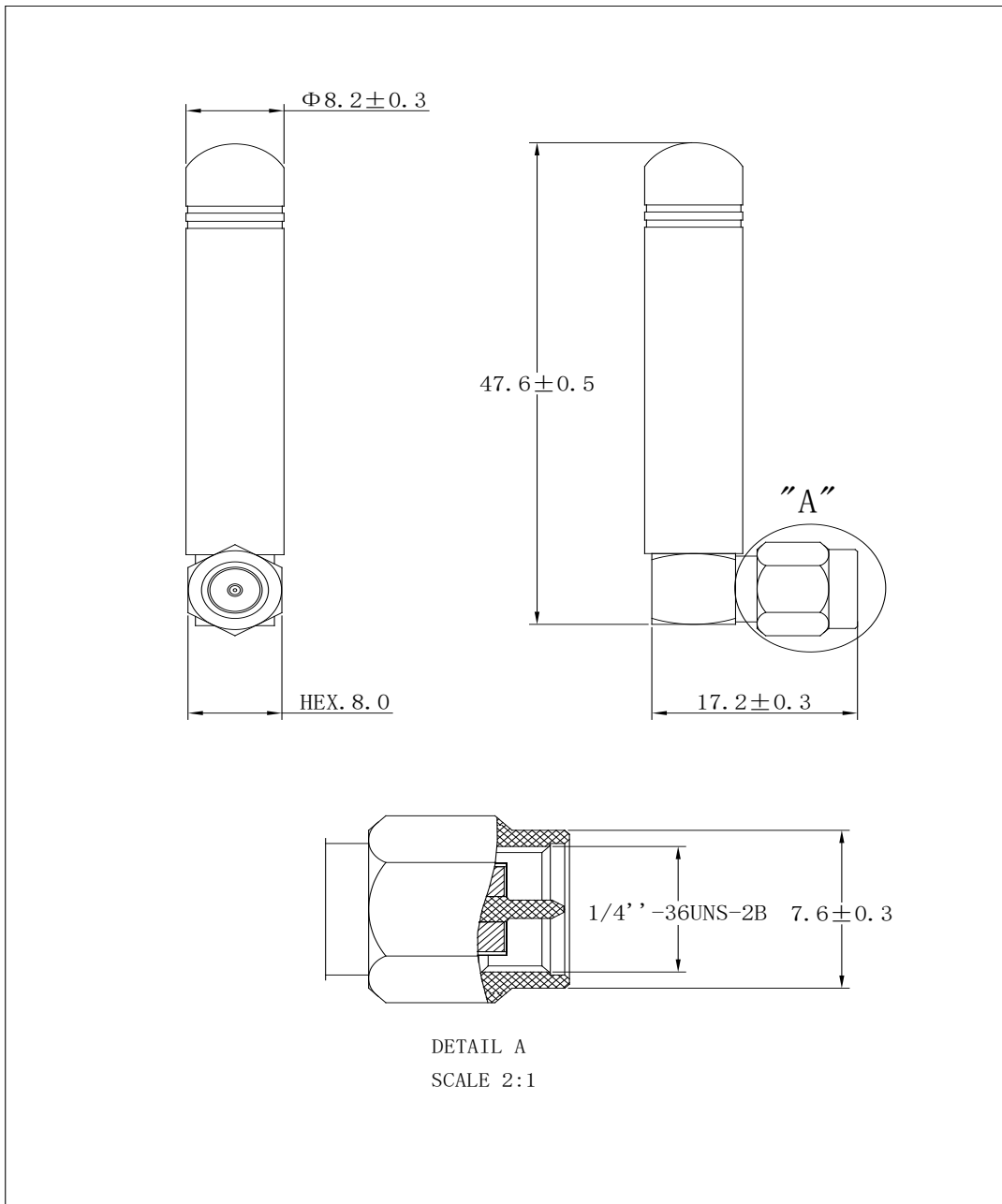

Aboosty™ is owned by Shenzhen MyAntenna RF Technology Co., Ltd. (often abbreviated as MyAntenna).